

LEVELING ADJUSTABLE HEIGHT ALUMINUM GANTRY - AHA-2-15-10-ALO

APPROX WEIGHT: 293.61 lbs.
DOES NOT INCLUDE WEIGHT OF POWER OR PACKAGING!!!

*** ANY ADDITIONS, DELETIONS, OR OMISSIONS MUST BE CORRECTED ON THIS DRAWING AS THIS DRAWING WILL BE CONSIDERED ALL INCLUSIVE ***
ALL GRAPHICS PROVIDED ARE FOR REFERENCE ONLY. IF CERTAIN DIMENSIONS ARE CRITICAL PLEASE VERIFY THOSE DIMENSIONS WITH YOUR SALESPERSON

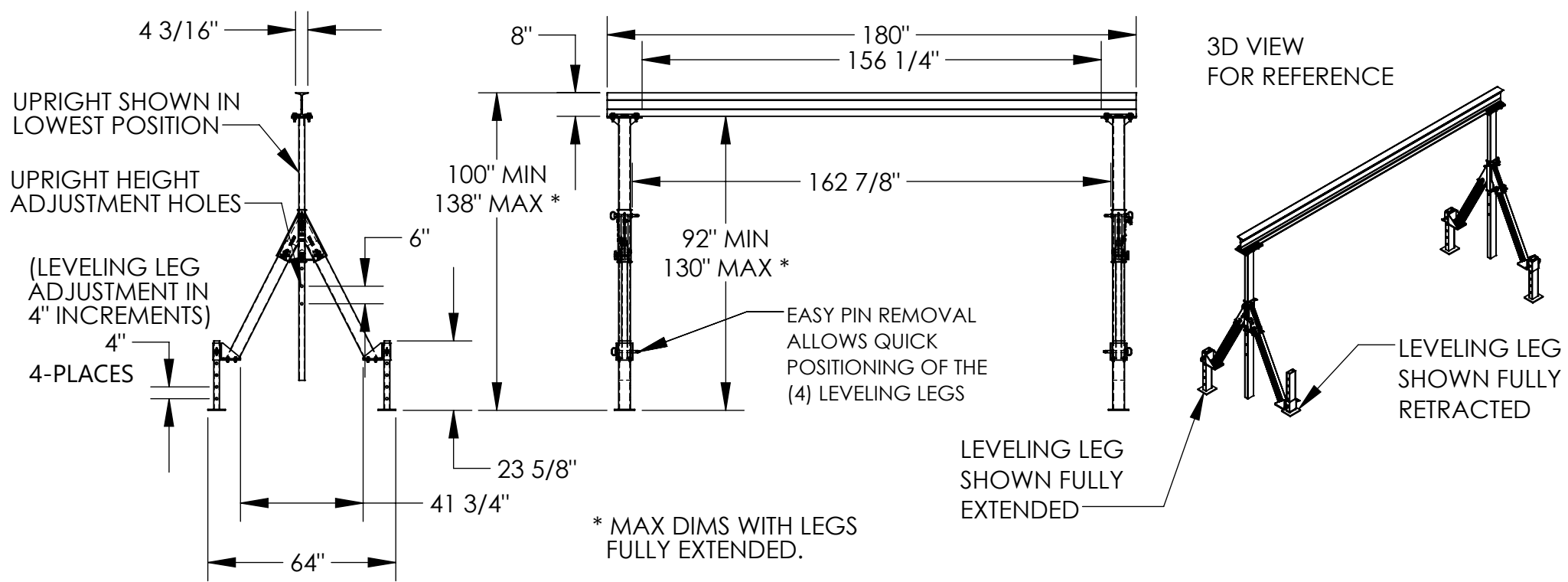

STANDARD FEATURES

MODEL NUMBER IS AHA-2-15-10-ALO
CAPACITY IS 2,000 LBS.
BASE WIDTH IS 64"
MAX OVERALL HEIGHT IS 138" *
I-BEAM SIZE IS 8" TALL WITH
4 3/16" FLANGE WIDTH
OVERALL I-BEAM LENGTH IS 180"
USABLE I-BEAM LENGTH IS 156 1/4"
LEVELING LEG HEIGHT IS INDIVIDUALLY ADJUSTED
UP TO 16" MAX. TO LEVEL CRANE
UNDER I-BEAM HEIGHT MAY BE ADJUSTED IN 6"
INCREMENTS USING THE 6 HOLES IN THE UPRIGHTS
ADJUSTABLE UNDER I-BEAM HEIGHT
92" MIN.
130" MAX. *
CRANE MAY BE TAKEN APART AND BUNDLED WITH
(2) INCLUDED STRAPS FOR EASY TRANSPORT
ALUMINUM CONSTRUCTION

SPECIAL FEATURES

NONE

DIMENSION TOLERANCE ± 1/4"

APPROVAL

I, THE UNDERSIGNED, AGREE THAT THE PRODUCT AS REPRESENTED SATISFIES DESIGN AND DIMENSION REQUIREMENTS. I ALSO ACKNOWLEDGE MY DUTY TO CONFIRM PRODUCT AND INSTALLATION COMPLIANCE WITH ALL APPLICABLE FEDERAL, STATE AND LOCAL REGULATIONS AND STANDARDS.
UNITS REQUIRING APPROVAL DRAWINGS OR MODIFIED ARE NON-RETURNABLE
[] As drawn [] As marked

Signed: _____ Date: _____

Printed Name: _____

LEAD TIME WILL START UPON RECEIPT OF SIGNED APPROVAL DRAWING

DISTRIBUTOR'S NAME:		P.O.#
VESTIL MANUFACTURING		X
DRAWN BY: MTS		W.O.#
DATE: 10/11/2019		X
REFERENCE: X	SCALE: 1:50	SALES: X
QUOTED LEAD TIME: X	QUOTE # X	FILE NAME:
		28-007-427